

USB/RS485 Communication Cable Installation

APPLICATION NOTE / MARCH 17, 2014 / 9C0900r4

Introduction

The purpose of this document is to provide instructions for using the INW USB/RS485 communication cable to connect your computer to AquiStar® Smart Sensors. This process will install the needed drivers.

The drivers for this cable are located on the CD that came with your adapter. They are also located on the Aqua4Plus installation CD for Aqua4Plus versions 1.9.6 or higher. Alternately, you can download them from our web site at <http://inwusa.com/technical-library/software-downloads/>.

IMPORTANT NOTES – PLEASE READ!

- You must have administrative privileges on your computer in order to install the drivers. If you do not, then contact your IT department.
- Install Aqua4Plus before installing the drivers. **INW highly recommends using Aqua4Plus 1.9.6 or higher.** If you do not have this version, you can install it from the CD that comes with this kit. Insert the CD. Navigate to the folder “Aq4Plus 1-9-6.” Click Setup.exe.
- If you are taking your computer into the field, we highly recommend that you install and test the cable before taking your computer to the field.
- **If you already have an FTDI driver installed, the installation wizard may skip some of the steps or may not come up at all. This is normal.** If no wizard or bubble comes up indicating you need to install drivers, then proceed to the Connect and Setup section.
- If you will be using this cable with a version of Aqua4Plus earlier than 1.9.2, or if you will be using it with Aqua4Push, please see Appendix A.

Introduction	1
Driver Installation for Windows XP.....	2
Driver Installation via the Internet.....	2
Driver Installation Without the Internet.....	2
Connection and Setup.....	4
Appendix A: Using with Aqua4Push or Older Versions of Aqua4Plus	4
Appendix B: Installing Drivers if You Do Not Have Aqua4Plus 1.9.6 or Higher.....	7



USB/RS485 Communication Cable Installation

APPLICATION NOTE / MARCH 17, 2014 / 9C0900r4

Driver Installation for Windows XP

Follow instructions in section “Driver Installation Without the Internet” below.

Driver Installation via the Internet

If you are connected to the Internet and do not have automatic device installation turned off, then this is the recommended method for Vista, Windows 7, Windows 8.0, and Windows 8.1.

Plug the cable into any available USB port. Your computer will automatically access the correct drivers from the Internet and install them.

If this does not work, then install the drivers as shown in the next section.

Driver Installation Without the Internet

If you are not connected to the Internet, do not have automatic device installation turned off, or have Windows XP, then this is the recommended installation method.

- Install Aqua4Plus 1.9.6 or higher.
- From the Utilities menu, select Advanced Utilities, and then click Install USB/RS485 Drivers.

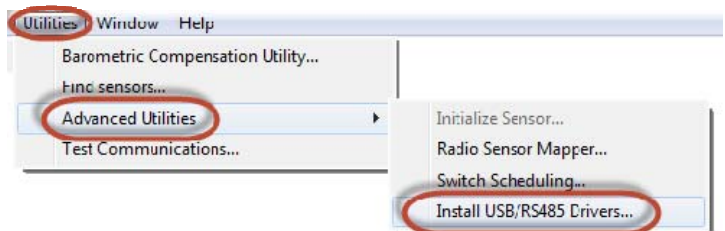

- Select your operating system, and then click Install.

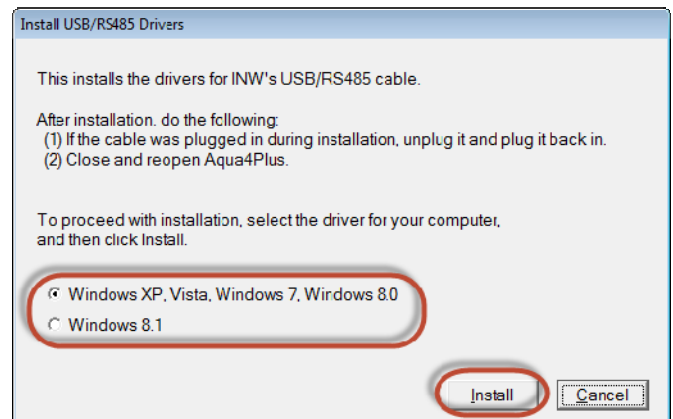

USB/RS485 Communication Cable Installation

APPLICATION NOTE / MARCH 17, 2014 / 9C0900r4

- The installation Wizard will open. Click Extract to begin the installation process.

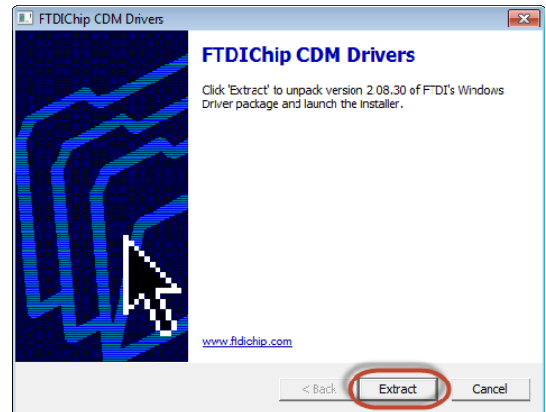

- Click Next on the Installation Wizard welcome screen.
- The drivers should begin installing.

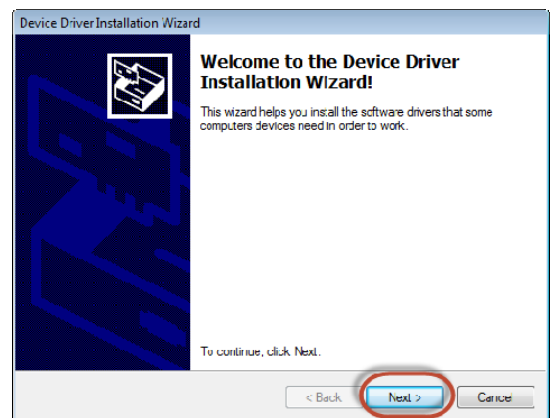

- Once complete, the Wizard will list the drivers installed. Click Finish.
- If the cable was connected to your computer during installation, disconnect it now and then plug it back in.

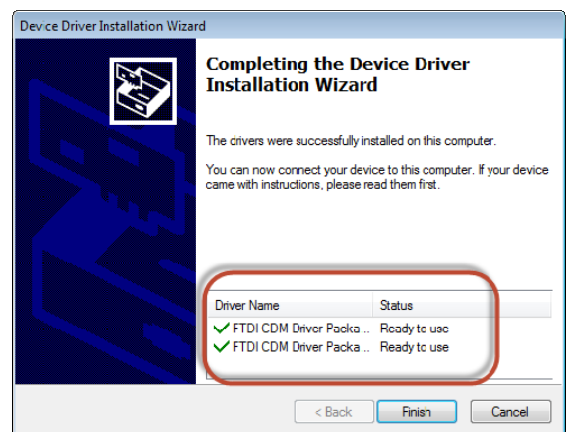

USB/RS485 Communication Cable Installation

APPLICATION NOTE / MARCH 17, 2014 / 9C0900r4

Connection and Setup

Once your USB/RS485 cable has been installed, you may remove it and reconnect it whenever you want, without having to reinstall the drivers.

- Connect to the Smart Sensor as shown below.

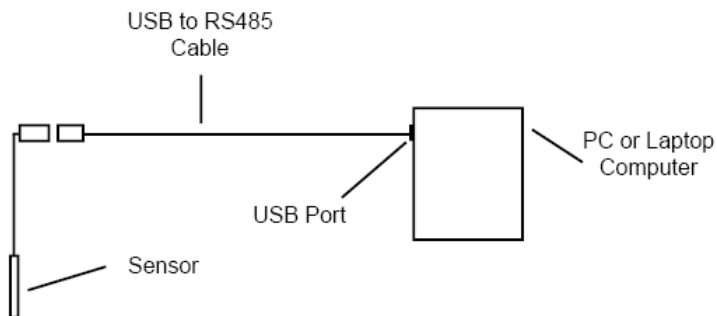

- In the Aqua4Plus software, select USB from the dropdown box on the tool bar.

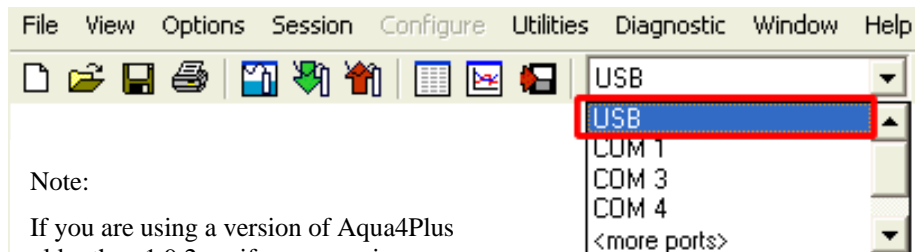

Note:

If you are using a version of Aqua4Plus older than 1.9.2, or if you are using Aqua4Push, refer to Appendix A.

USB/RS485 Communication Cable Installation

APPLICATION NOTE / MARCH 17, 2014 / 9C0900r4

Appendix A: Using with Aqua4Push or Older Versions of Aqua4Plus

If you are using your cable with Aqua4Push or a version of Aqua4Plus prior to version 1.9.2, you will need to determine the COM port to which your cable is connected and then select this COM port in the software.

Determining the COM Port

If you are using Windows 7 and you noted the COM port during installation, proceed to Selecting the COM Port, on the following page.

Other wise, you can determine the COM port as follows.

- Click the Start button.
 - **Right**-click on “Computer” or “My Computer.”
 - Click on “Manage.”
-
- In the left pane, click on “Device Manager.”
 - In the right pane, open “Ports.”
 - You should see an entry that says “USB Serial Port” followed by a COM port number. Make note of this COM port number.

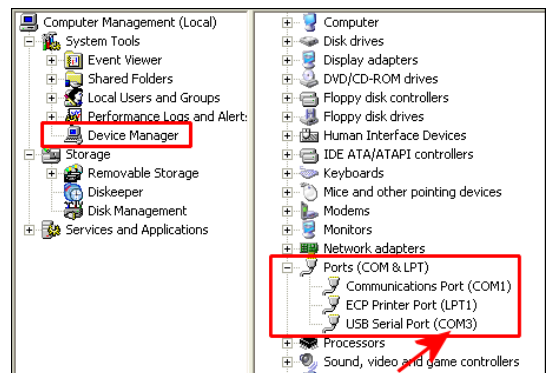
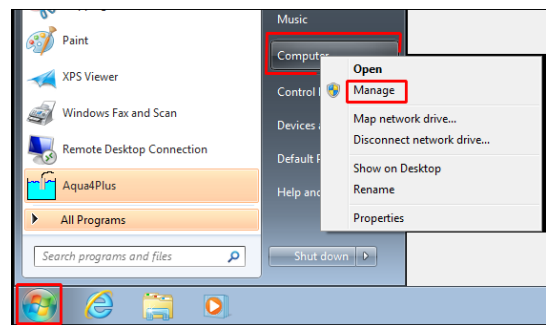

USB/RS485 Communication Cable Installation

APPLICATION NOTE / MARCH 17, 2014 / 9C0900r4

Selecting the COM Port

In Aqua4Plus

In the Aqua4Plus software, from the drop-down box on the tool bar select the COM port you identified above.



Note: If you do not see your new COM port in the drop-down box, open the Communications box from the Options menu. Increase the Highest COM port number. COM port numbers must be 15 or lower. If your cable installed on a COM port higher than 15, you will need to remap your COM port. Contact your IT department if this is needed.

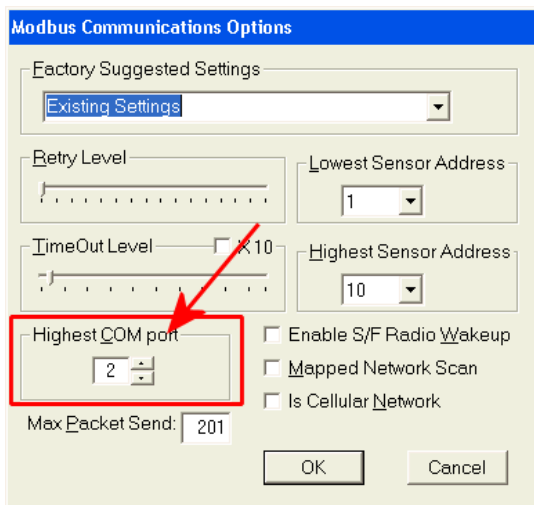

USB/RS485 Communication Cable Installation

APPLICATION NOTE / MARCH 17, 2014 / 9C0900r4

In Aqua4Push

In Aqua4Push, set the COM port in the Sensor Map. (See the Aqua4Push instruction manual for details on creating/editing Sensor Maps.)

- Select the main “Connections and Sensors” tab.
- On the right panel, select the “Communications Options” tab.
- Enter the COM port number.

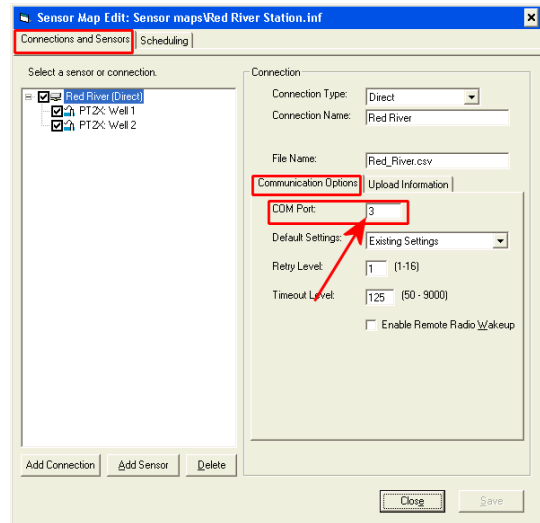

Appendix B: Installing Drivers if You Do Not Have Aqua4Plus 1.9.6 or Higher

If you do not have Aqua4Plus 1.9.6 or higher, or do not want to install it, install the drivers as follows:

Download the drivers from our web site at <http://inwusa.com/technical-library/software-downloads/> or access them from the CD supplied with this cable.

Two versions are available. If you have Windows 8.1, run *CDM v2.08.30 WHQL Certified for Windows 8.1.exe*. Otherwise, run *CDM20830_Setup.exe*. Note: you should run these as Administrator. (Contact your IT department, if you need further help on Administrator mode.)



AquiStar is a registered trademark of Instrumentation Northwest, Inc.
Windows is a registered trademark of Microsoft Corporation.