

## Advanced Peristaltic Pump



## Contents

1. Short description .....	1
2. Using the pump for the first time .....	1
3. Using the peristaltic pump .....	2
3.1 Switching on .....	2
3.2 Direction of rotation .....	2
3.3 Rate of revolution .....	2
3.4 Rate of revolution memory functions .....	3
3.5 Switching off .....	4
3.6 Charging the internal battery .....	4
3.7 External power supply .....	4
3.8 External pump .....	5
4. Using the peristaltic pump .....	5
4.1 Type of tube .....	5
4.2 Inserting the tube .....	6
5. Defects and maintenance .....	7
5.1 Defects .....	7
5.2 Maintenance .....	9
Appendix: Connection external power supply / battery charger .....	10

## Advanced Peristaltic Pump

### 1. Short description

This peristaltic pump suitable for use in the field is battery-powered and microprocessor controlled. The microprocessor ensures a constant yet adjustable rate of revolutions, protection against overload and a number of external control functions. A built-in maintenance-free 12 volt lead-acid battery makes possible continuous use of the pump for periods of between 2 and 5 hours (dependent on the load). The housing is splash-proof (IP64) and can be used safely and without problems out-of-doors. The apparatus may be used in all positions.

The pump has been designed for long term professional use under adverse conditions. High quality materials have been used in its manufacture.

The built-up pump is a simple but very durable peristaltic pump with three pressure rolls. The pump is mechanically very powerful.

**Never stick your fingers into a revolving pump!**

### 2. Using the pump for the first time

Peristaltic pumps which leave our factory are subjected to very strict final inspection. After delivery, check first that the pump and battery charger have not suffered damage during transport. Loose components in either the pump or the charger indicate damage. You can check on this by manipulating them gently from side to side; do not open them. In the case of damage you should contact your supplier. Do not use the pump until first reading these instructions. Keep these instructions in a place accessible to all users.

Use of the pump in places where there is a danger of explosion is not permitted. Charge the battery for the first time after delivery of the pump. This saves disappointment on the first working day!

The battery is charged by connecting the accompanying charger to the External battery / Charge socket on the front panel of the pump. The red indicator lamp remains lit during the charging period. Depending on the battery's condition of charge, this indicator will go out after a certain period of time. (after this only so-called trickle charging takes place). The pump is then ready for use.

## Advanced Peristaltic Pump

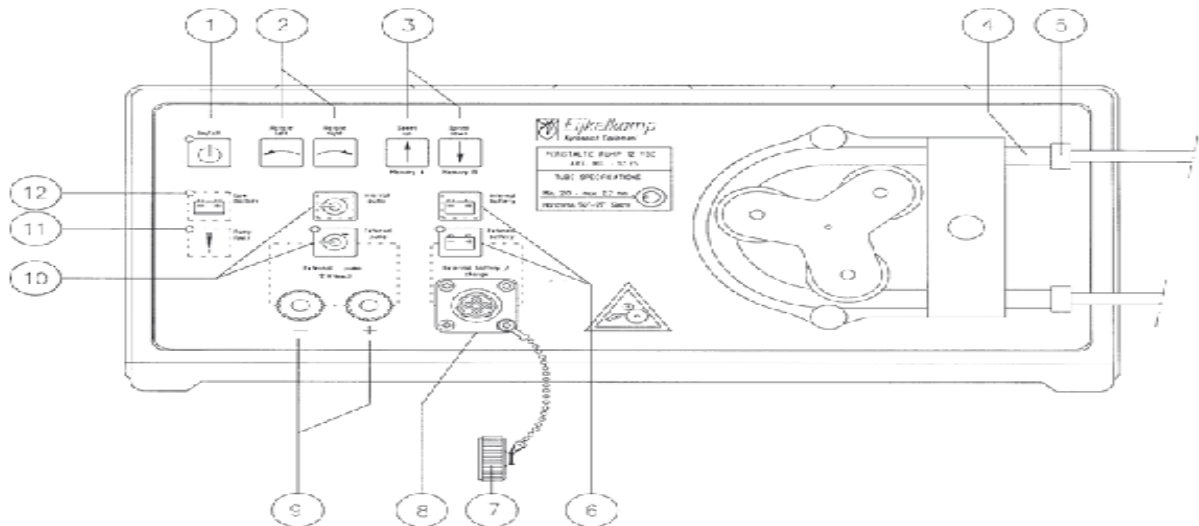

- |   |  |  |
|---|--|--|
| <ul style="list-style-type: none"> <li>1. On/Off switch with indicator</li> <li>2. Pump direction of rotation</li> <li>3. Speed control<br/>+memory A en B</li> <li>4. Flexible tube</li> </ul> | <ul style="list-style-type: none"> <li>5. Clamp</li> <li>6. Selection switches for internal/external battery</li> <li>7. Watertight closing cap</li> <li>8. Connection for external supply/battery charger</li> <li>9. Connection for external pump</li> </ul> | <ul style="list-style-type: none"> <li>10. Selection switches internal/external pump</li> <li>11. Pump defect indicator/<br/>condensatie indicator</li> <li>12. Battery low indicator</li> </ul> |
|---|--|--|

### 3. Using the peristaltic pump

The operation of the peristaltic pump takes place by means of the switches on the front panel. The switch panel is laid out clearly and the switches are provided both with text and logical markers. The control switches are so-called membrane key-pads which have a palpable instant of engagement. They only need to be pressed in order to perform the switch function.

#### 3.1 Switching on

Switching on the peristaltic pump takes place using the On/off switch. After switching on the green indicator will light up. The pump will not start up immediately after being switched on because of safety reasons.

#### 3.2 Direction of rotation

Choose the required direction of rotation for the pump by using the Rotate left or Rotate right switch. After switching on the pump, the direction of rotation is to the right. If this is the direction you require, there is no need to engage this switch. The direction of rotation can be altered during pumping without first stopping the pump.

#### 3.3 Rate of revolution

The rate of revolution can be speeded up using the speed-up switch. The pump will now begin to operate. Pressing the touch key once will have the effect of increasing the speed by ca. 10 revolutions per minute. If you keep the touch key depressed, the speed will reach maximum revolutions in approximately 5 seconds. Using the speed down key, the speed decreases in a similar manner. In case of problems, switch off the machine by using the On/off switch.

## Advanced Peristaltic Pump

### 3.4 Rate of revolution memory functions

The peristaltic pump (art. no. 12.25) has been fitted with two rate of revolution memory functions. This allows for the definition of fixed individual speeds for instance for purging and sampling. Two speed memories have been included, a rate of revolution A memory and a rate of revolution B memory.

The rates remain stored in the memory, even if the pump is switched off. Every single rate with the direction of rotation belonging, can be recorded.

Programming the speed memory:

1. Switch off the appliance with the On/Off button
2. Press keys Memory A (Speed up) or Memory B (Speed down) for 3 to 6 seconds while you start the pump with the On/Off button. After releasing the Memory A (Speed up) or Memory B (Speed down) key the function setting memory has been activated, the pump does not turn. The direction of rotation as well as the speed can now be set. The speed can be increased step-wise with 10 rpm by briefly pressing the Speed up key. On switching off using the On/Off key the set speed and direction of rotation are recorded in the A memory. If no speed (speed = 0) is set, the previous setting will be maintained.

Starting with the rate as recorded in memory A or B (pump is off):

Keep the key Memory A (Speed up) or Memory B (Speed down) pressed down during a short time (0 to 3 seconds) at the very moment the pump is switched on with the On/Off key. After releasing the key the pump will start rotating in the determined direction of rotation and brings the speed up to the level stored in memory A or B.

Additional memory function in operational position:

This quality can be observed as a way to temporarily shut down the pump and start it again with the use of the rate of revolutions used before, without switching off or using any other memory functions.

When the pump is in use, the set speed and direction of rotation are maintained when switching to external battery (a failure condition occurs caused by the absence of an external battery (Low Battery) and the pump stops). By switching to internal battery, the pump will start running again with the direction and speed set before the failure condition.

The rate of revolution and direction of rotation are also maintained when switching to external pump (a failure condition occurs due to absence of the external pump (LED External pump is blinking) and the internal pump stops). On correcting the previous failure by switching to internal pump, the pump will start running again with the direction and speed set before the failure condition.

## Advanced Peristaltic Pump

### 3.5 Switching off

Switching off the pump takes place with the On/off switch. When the pump has not been used for an hour or more and the revolutions are at zero the pump will automatically switch off.

### 3.6 Charging the internal battery

When charging the internal battery use only the accompanying battery charger. Other chargers, such as car-battery chargers can cause damage to the pump. Charging the pump in places where there is a danger of explosion is not permitted.

The pump is supplied charged and tested. The battery can be recharged at any moment (does not need to be empty). The battery charger can remain connected even if the battery is full. Recharging the battery after every use of the pump lengthens the lifetime of the battery. Even if the pump is not used, the battery must be charged at least once every month.

In order to guarantee the lifetime of the 12 volt battery (art. no. 12.25.02) this has been protected against being entirely discharged. Where the battery voltage falls below 10.5 volts the pump switches off and the red battery low indicator lights up. The battery should now be charged (with battery charger 12.25.21). Connect the plug of the battery charger to the combined External battery/Charge socket. The battery charger stops charging when the battery is full (normally after 14 to 48 hours) and then automatically changes over to so-called trickle charge. The indicator is then off or lights up very soft. The charger can remain connected to the pump without danger of over-charging of the battery. For safety reasons the battery is built into a separate gas-tight space which has its own ventilation to the outside air so that battery gases cannot accumulate in the housing. Where the peristaltic pump is in intensive use and the battery needs to be charged daily, it is advisable to have the battery charger adapted for this purpose by Eijkelkamp. This adaptation consists of raising the charge voltage supplied by the battery charger. This prevents an undesirable shortening of the life of the battery where there is intensive use. The adaptation of the battery charger has the consequence that the battery may no longer be kept connected to the battery charger for an unlimited time.

### 3.7 External power supply

An external 12 volt battery with a minimum capacity of 6 Ah can be connected to the External Battery / Charge connector by means of a cable. This cable has a 0.5 volt loss of voltage at normal current consumption of 2.5 amps. If problems arise a thicker and/or shorter cable can be used.

Connection to an external battery:

The high power consumption of the pump causes a high current at 12 volts. This restricts the distance that may exist between the peristaltic pump and the external battery. The cable may be connected either to the external battery 12.25.02 or to a vehicle's cigarette lighter. The external power supply is switched on by choosing the external battery switch. The internal battery is simultaneously switched off.

## Advanced Peristaltic Pump

### 3.8 External pump

It is possible to connect a 12 volt submersible pump (Art. no. 12.12.06 and 12.12.08) to the External Pump connectors. This output is fuse-protected to a maximum current of 6 Amps and can supply up to two of these submersible pumps. The revolution rate of the pumps is adjustable by means of the control keys. The polarity at the connection of the submersible pumps is not important; the pump functions equally well in either direction (see submersible pump manual) In the case of other pumps the positive (+) 12V should be connected to the red (+) positive contact and the 0 V should be connected to the black (-) negative contact. It is not possible to use the pump of the peristaltic pump together with an external pump.

### 4. Using the peristaltic pump

A peristaltic pump is both a gas and liquid pump. The pump is self-priming. Even when the pump is not turning, the tube is compressed entirely by one of the rollers. Fluid or gas can therefore never flow back. Flexible tubes having different diameters and chemical properties can be used in the pump. The rollers roll the gas or fluid out of the tube so that they are expelled from the pump tube. Behind the roller the tube then springs up once more and sucks new gas or fluid inside.

If you use the pump in rainy weather, you should take care to completely protect the peristaltic pump from the rain. A slippery flexible tube will cause pumping problems. You should at least place the pump face down in rainy weather, supported by the carrying strap. Water will not then be able to accumulate on the front panel. Make sure that water cannot penetrate the battery compartment through the ventilation opening. The transparent cover plate must always be on the pump to prevent damage of the bearings by dirt and moisture. Think about safety: the pump is very powerful. The cover plate prevents shifting of the tube (loss of pressure and suction power).

**Never stick your fingers into a revolving pump!**

#### 4.1 Type of tube

The pump is designed for use with elastic pump tubes where the total (= double) wall thickness is 4.0 to 4.4 mm thick. The rigidity of the flexible tube must be between 50 and 55 degrees Shore. The stronger the flexibility, the stronger the suction. Therefore the thinnest pump tube has the greatest suction (full vacuum). Normally speaking only the relatively expensive flexible silicone rubber is used in the pump. As transport tube polyethylene or sometimes the very expensive but inert teflon is used as tube material. Where the tube must be able to resist a high pressure (for example during in-line filtration) the pump tube needs to be protected against coming loose by using a tube clamp. This is not necessary on the suction side.

The thinnest tube for use in the pump has a diameter of 4 x 8 mm, with a suction power equivalent to a Meter Water Column (mwc) of 8 - 9.5 meter. The pressure exerted reaches 25-30 mwc and the flow rate is maximal 1 l/min at 400 rpm.

## Advanced Peristaltic Pump

Art. No.	Material	Size	Length
12.20.02	Polyethylene tube,	diameter 2 x 4 mm,	roll of 100 m
12.20.03	Polyethylene tube,	diameter 4 x 6 mm,	roll of 100 m
12.20.04	Polyethylene tube	diameter 6 x 8 mm,	roll of 100 m
12.20.05	Polyethylene tube,	diameter 6 x 8 mm,	roll of 200 m
12.20.08	Polyethylene tube,	diameter 8 x 10 mm,	roll of 100 m
12.20.13	Polyethylene tube,	diameter 10 x 12mm,	roll of 75 m
12.20.22	Teflon tube,	diameter 2 x 4 mm,	roll of 10 m
12.20.28	Teflon tube,	diameter 8 x 10 mm,	roll of 10 m
12.20.32	Teflon tube,	diameter 10 x 12 mm,	roll of 10 m
12.20.46	Silicone tube,	diameter 4 x 8 mm,	roll of 5 m
12.20.48	Silicone tube,	diameter 2 x 4 mm,	roll of 5 m

The normal tube has a diameter of 6 x 10 mm, suction of 6 - 9 mwc a pressure of 25-30 mwc and a flow rate of 2.4 l/min (maximal, without discharge head and suction height).

The indicated values may vary because of tolerances in thickness and rigidity of the tube. They apply only as indication values for the silicone tube.

The much used 6 x 10 mm silicone tube should preferably be used in combination with the 6 x 8 mm PE tube.

The PE or teflon tube in the 8 x 10 mm size may also be fitted inside this silicone tube.

The PE or teflon tube in size 10 x 12 mm may if necessary be fitted over this silicone tube The 4 x 8 mm silicone tube can if necessary be used with the same 6 x 8 mm PE tube.

The 2 x 4 mm PE or teflon tube is a little easier to work with. This fits inside the silicone tube but has a very high through-put resistance to water. (limited flow rate and high pressure in long flow lines). The 2 x 4 mm PE (or teflon) tube is more suitable for pumping gas. The 4 x 6 mm PE tube can be used either with the 6 x 8 mm silicone tube as well as with the 4 x 8 mm silicone tube. In combination with the latter silicone tube the 4 x 6 mm PE tube can very well be used to pump up water from wells where the water level may reach 9.5 m.

Sampling for the purposes of analysis on micro-parameters should be carried out changing both the pump tube and the polyethylene transport tube before each sampling operation in order to avoid risks of cross contamination. An exception can be made in the case of the teflon tube. This expensive but chemically stable tube can usually be used again after a thorough cleaning.

### 4.2 Inserting the tube

Switch off the pump before inserting the tube.

After removing 28 to 30 cm of pump tube this may be inserted in the pump by carefully removing the pump's cover plate and unfastening the pressure clasp. By evenly turning the pressure rollers with the fingers, the tube may be laid in place.

**Never stick your fingers into a revolving pump!**

## Advanced Peristaltic Pump

There is also an alternative method. Turn on the pump and allow it to run. Loosen the pressure clasp and take out the old pump tube. (following the direction of the pump). The new piece of tube is then inserted in the same way. The tube must be well gripped by the pressure clasp. Otherwise the tube will be slowly pulled inwards by the pump. This can block the motor and stop the operation of the pump.

Pump housing, rollers and tubes should be always dry and maintained in a dry condition during operation of the pump. This prevents the tube being pushed aside by the rollers during pumping. When this happens only a small fraction of the original suction and pressure power remains.

### 5. Defects and maintenance

#### 5.1 Defects

Since only high quality components are used in the manufacture of the pump, in ordinary proper use you will only have problems very exceptionally. Safety protections have been fitted to the pump in order to prevent damage through overloading, short circuit or faulty use. The overview below has been drawn up to provide quick help in case of any problems.

The pump is switched on but the On/off indicator fails to light up

- The battery is completely empty. From the practical point of view this can only happen where the battery has an internal closed circuit or the pump has been stored for a very long time without being recharged. The battery should be charged or replaced.
- As a result of overloading the internal self reset protection is activated. Overloading of the battery can occur by connecting it with the wrong kind of battery charger or by short circuiting the External battery / Charge connection. In this case the internal self reset protection is activated. First locate and deal with the cause! The pump may be switched on again after 1 minute.

Battery low indicator flashes

- The battery is almost empty, charge the battery or connect an external power source. The pump has stopped, battery low indicator is on
- The battery is empty; charge the battery or connect an external power source followed by turning off the pump using the On/off switch and then turn it on again.
- After being charged, the battery quickly becomes empty
- Connect the battery charger to the mains and to the External battery / Charge connection. The indicator on the battery charger should light up. If the indicator goes out after a short time the problems should be sought in the battery.



## Advanced Peristaltic Pump

- The battery is worn or faulty and needs to be replaced. For the time being use can be made of an external battery.

External battery selected, Battery low indicator is on and the External battery indicator flashes

- The external power source voltage is too low, no external power source is connected or the external power supply potential is reversed. Solve these problems and turn off the indicator light using the internal battery switch.

The pump suction and pressure are insufficient

- The housing and rollers are wet. Dry the pump housing, rollers and pump tube. Prevent the pump from becoming wet again (Cover up the pump).
- The tube has shifted position in the pump housing and therefore is running alongside the rollers (it is especially the 4 x 8 tube which is liable to this). Remove the tension from the tube by releasing the tension clasp and tightening it again.
- Make sure you are using the proper sort of pump tube. Check the wall thickness of the pump tube.
- Pump housing is deformed. Check the distance of the inside of the pump housing till the centre of the black synthetic rollers (= round synthetic plate with hole on the end of the main drive shaft).

The distance must be the same everywhere (+/- 0.15 mm). Use a caliper gauge.

- The transparent cover plate must always be on the pump to prevent damage of the bearings by dirt and moisture. Think about safety: the pump is very powerfull. The cover plate prevents shifting of the tube (loss of pressure and suction power).

The pump turns itself off after a short while, the Pump fault indicator is on and the On/off indicator is flashing

- The motor is too heavily loaded or is congested. The protection turns off the pump. Make sure no sand has been sucked into the pump tube or that the pump is not blocked in some other way. First remove the cause of the overload. The protection can be reset by switching the pump on and off with the On/off switch.

The internal motor is running, but not the pump

- The coupling between the motor and the pump may be loose. Refasten this using a small screwdriver. The base plate of the housing needs to be removed to perform this operation.

## Advanced Peristaltic Pump

The External pump indicator flashes

- The external pump function is selected but no external pump is connected. Check the connection and turn off the indicator with the internal pump switch.

Pump fault indicator flashes, but the pump is functioning in a normal way

- There is condensation in the pump housing; the pump must be checked as soon as possible, to prevent damage of the electronics.

### 5.2 Maintenance

This equipment has been designed to make sampling possible under field conditions. These samples may be used for the purpose of very exact and extremely sensitive analyses. A clean piece of equipment stimulates the proper ways of working during sampling. A well maintained machine looks better and lasts longer.

Regularly clean the peristaltic pump, the cover plate, rollers and pressure clasp using a damp cloth. The front panel and the housing can be cleaned using a soft damp cloth and a non-abrasive cleaning agent where necessary.

Never use abrasive cleaning agents or solvents when cleaning the pump! It is recommended that where the pump is being used almost daily, it should be given a service each year by the supplier.

## Advanced Peristaltic Pump

### Appendix: Connection external power supply / battery charger

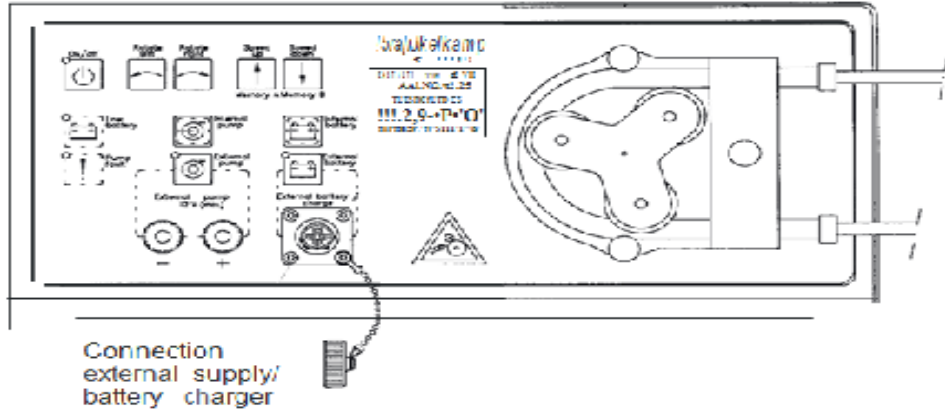

- External supply or battery
- 1 red, ext. batt. +
  - 2 do not connect
  - 3 black, charge / ext. batt. -
  - 4 do not connect

- Battery charger
- 1 do not connect
  - 2 red, charge + max. 1 Amp.
  - 3 black, charge / ext. batt. -
  - 4 do not connect

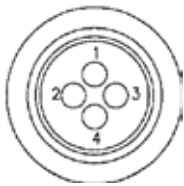

View of mounting side connector

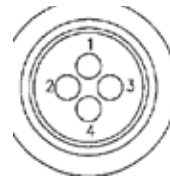

View of mounting side connector

#### Power supply mains

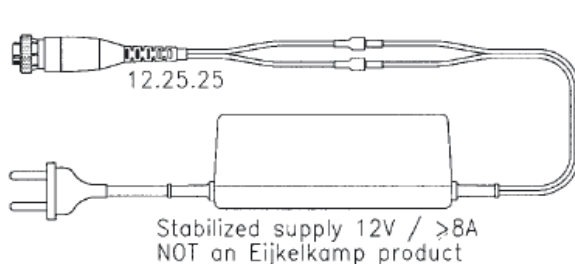

#### Charging internal battery

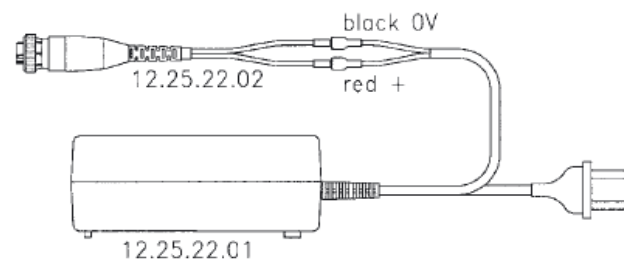

#### Power supply with external battery

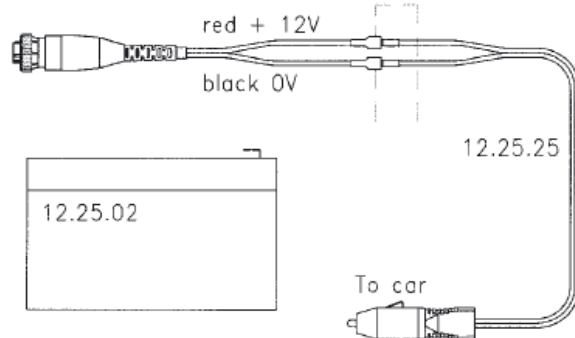

#### Charging external battery

