

Global Data Transmitter Multiple GPRS/UMTS

User manual
(Original instructions)

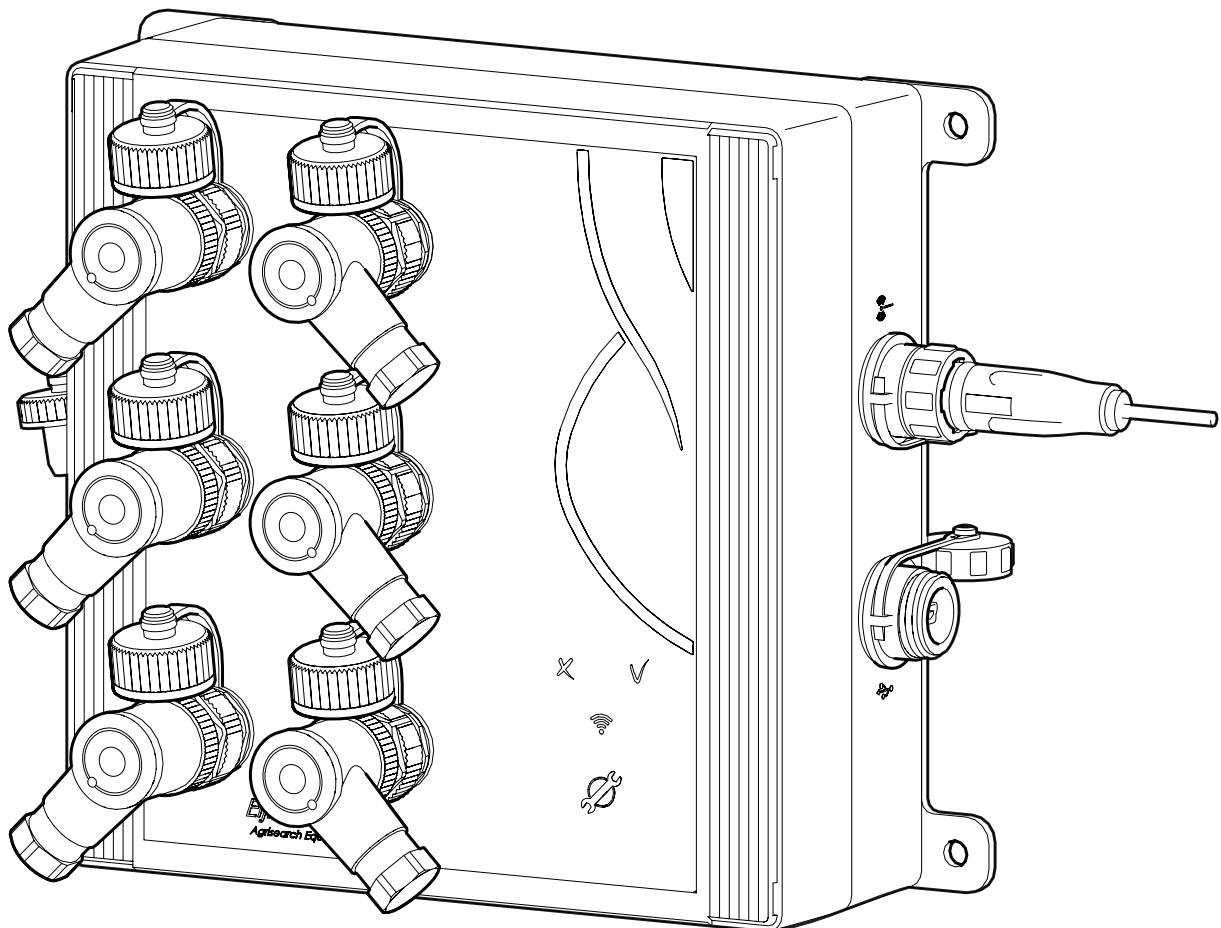

Disclaimer

Nothing from this document may be copied and/or made public by means of printing, photocopy, microfilm or in any other way without the prior written approval of the publisher.

Technical data can change without prior notification.

Eijkelpark Agrisearch Equipment is not responsible and/or liable for any damage and/or personal injury due to (incorrect) use of this product.

Eijkelpark Agrisearch Equipment would be pleased to receive your reactions and comments about this product and the user instructions.

Table of contents

1 Introduction

1.1	How to use this manual	5
1.2	Original instructions	5
1.3	Working principle	5
1.3.1	e-SENSE system	5
1.3.2	Data communication overview	6
1.3.3	Communication intervals	7
1.3.4	Modem	8
1.3.5	Back Office	8
1.3.6	Web portal	9
1.3.7	E-mail functionality	9
1.4	Service and support	9
1.4.1	Qualified personnel	9
1.4.2	Contact details	10

2 Safety

2.1	Symbols in the manual	11
2.2	Intended use	11
2.3	Qualification of the user	11
2.4	Liability	12
2.5	Regulations and instructions	12
2.5.1	Modem	12
2.5.2	Battery pack	13
2.5.3	External power supply	13
2.5.4	Connection	13
2.6	Environment and disposal of waste	14
2.6.1	Correct disposal of the product	14
2.6.2	Correct disposal of the battery pack	14

3 Product overview

3.1	Outside view	15
3.2	Inside view	16
3.3	Explanation of the controls	16
3.3.1	Service button	17
3.3.2	Connection LED	17
3.3.3	Error LED	17
3.3.4	GSM signal strength LED	17
3.4	Technical data	18
3.4.1	Mechanical specifications	18
3.4.2	Electrical specifications	18
3.4.3	Connections	19
3.4.4	Ambient conditions	20
3.4.5	Certifications	20

4	Getting started	
4.1	Unpacking.....	21
4.2	Installation	21
4.2.1	Mounting the modem.....	21
4.2.2	Connecting the antenna	22
4.2.3	Connecting a sensor cable.....	23
4.2.4	Connecting the external power supply (optional)	23
4.3	Commissioning	24
5	Maintenance	
5.1	Preparation	25
5.2	General inspection overview	25
5.3	Inspection and cleaning.....	26
5.3.1	Inspecting and cleaning the outside of the modem	26
5.3.2	Dismounting the modem	26
5.3.3	Opening the enclosure	27
5.3.4	Checking the Humidity Indicator Card.....	28
5.3.5	Inspecting and cleaning the inside of the modem	29
5.3.6	Replacing the desiccant kit.....	29
5.3.7	Closing the enclosure.....	30
5.3.8	Mounting the modem.....	31
5.4	Replacing the battery pack	32
5.5	Replacing the SIM card (optional)	33
5.6	Storage	34
6	Specifications	
6.1	Parts list.....	35
6.2	Dimensions	36
7	Declaration of Conformity	
7.1	EC Declaration GSM / GPRS	37
7.2	EC Declaration UMTS	38

1 Introduction

1.1 How to use this manual

This manual is intended as a reference manual by which users can use and configure the Global Data Transmitter multiple GPRS (or Global Data Transmitter multiple UMTS), henceforth called the modem. Make sure you have read and understood the manual before you use the modem. For an overview of the modem and its components, refer to chapter 3.

Make sure that you

- know the contents of this manual;
- follow up all directions;
- do not change the sequence of the procedures.

1.2 Original instructions

The original instructions for this manual have been written in English. Other language versions of this manual are a translation of the original instructions.

1.3 Working principle

1.3.1 e-SENSE system

The purpose of the e-SENSE system is to collect data of measurements in the field. The e-SENSE system works by means of a wireless data connection to the GSM network (GPRS or UMTS¹⁾). The data connection is encrypted to prevent unwanted access. The e-SENSE system consists of sensors (e+ loggers and/or Divers), the modem, and the Back Office. The communication between these devices and their function will be discussed in the following sections.

1) UMTS is optional.

1.3.2 Data communication overview

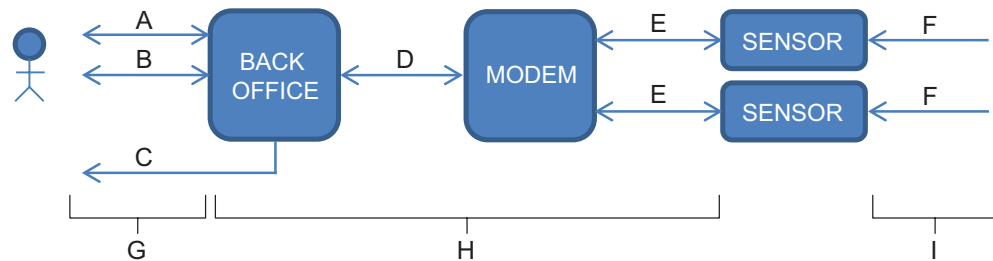

- A Web portal
- B E-mail
- C SMS alarm
- D GSM network
- E Sensor cable
- F Sensor measurement
- G Send interval
- H Wake-up interval
- I Measurement interval

Device / tool	Communication	Activity	Refer to
Sensors	Sensor cable	<ul style="list-style-type: none"> • perform the measurements • store data 	
Modem	Sensor cable GSM (UMTS is optional)	<ul style="list-style-type: none"> • intermediates between the Back Office and up to 6 sensors • communicates with the Back Office • the internal barometer measures the air pressure and temperature 	1.3.4
Back Office	GSM (UMTS is optional)	<ul style="list-style-type: none"> • communicates with the modem and its connected sensors • collects and stores data • configures the modem and sensor settings 	1.3.5
Web portal E-mail	Internet	<ul style="list-style-type: none"> • user can configure modem and sensor settings • receives data from the Back Office • user can view the status of the modem and sensor(s) 	1.3.6 and 1.3.7

Introduction

1.3.3 Communication intervals

The following figure shows an example of how the various communication intervals between the devices can be arranged.

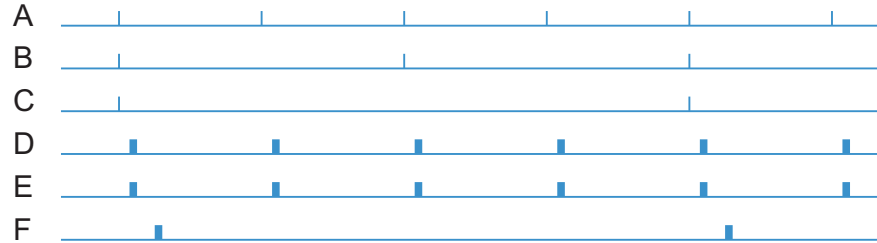

- A Measurement interval of sensor 1
- B Measurement interval of sensor 2
- C Measurement interval of sensor 3
- D Wake-up interval
- E Measurement interval of internal Barometer (not modifiable)
- F Send interval

Measurement interval

A measurement interval is the interval between two sensor measurements of a sensor. The measurement interval can be adjusted per sensor, so each sensor has its own measurement interval.

Wake-up interval

The wake-up interval is the frequency in which the modem starts up (wakes up from sleep mode) to intermediate between the Back Office and the connected sensors.



Note

SMS messages are only sent in case of an alarm situation (and hence not in a specific interval).

Send interval

The send interval is the frequency with which the Back Office sends the new data to the user or the Web portal.

1.3.4 Modem

For an overview of the modem and its components, refer to chapter 3. The modem is the connecting element between the sensors and the Back Office in the e-SENSE system. The modem is designed to obtain measurement data from a central location without having to travel to the location(s) where the sensors are placed. The modem will periodically become active at wake-up intervals and log into the Back Office.

The most important functions of the modem are:

- Transporting sensor data of the connected sensors to the Back Office;
- Enabling remote monitoring and control of the connected sensors.

The most important features of the modem are:

- No software needed;
- Global connectivity;
- Easy 'plug-and-play' installation;
- Internal barometer;
- Multiple sensors can be connected.

There are two methods to get access to the modem. The following table gives an overview.

Option	Tool	Refer to
Web portal	Web browser	Supplement 1
E-mail functionality	E-mail addresses	Supplement 2

1.3.5 Back Office

The Back Office is designed to control the modem and its connected sensors. The following table gives an overview.

Type of control	Specification
Communication	Collecting data at wake-up intervals
Monitoring	Checking the status
Configuration	Changing the settings
Alarming	Sending an e-mail and/or SMS notification in case the user-defined or predefined limits are exceeded

Introduction

1.3.6 Web portal

The web portal is designed to give easy access to the Back Office.

The web portal:

- Gives quick access to the data;
- Has a user-friendly interface to configure the modem and sensor settings.

Requirements:

- Internet access;
- Web browser;
- User account to log into the web portal.



Note

Refer to Supplement 1 for detailed information on how to use the web portal.

1.3.7 E-mail functionality

The user can communicate with the modem by sending an e-mail to the Back Office. The e-mail interface is meant for advanced users of the modem.

Requirements:

- Internet
- A user e-mail address
- A modem e-mail address



Note

Refer to Supplement 2 for detailed information on how to use the e-mail functionality.

1.4 Service and support

1.4.1 Qualified personnel

Eijkelkamp maintains a staff of experienced service personnel. Their expert knowledge could be of assistance at inspection, installation, or repair activities.

For information with respect to specific adjustments, installation, maintenance or repair jobs, which fall beyond the scope of this manual, contact Eijkelkamp.

Make sure you have the following data at hand:

- Product code²⁾
- Date of manufacture
- Serial number
- Date of purchase
- Invoice number

2) The product code can be found in the footer of every page. The product code starts with an M.

1.4.2 Contact details

The address and contact details can also be found at the back of this manual.

Eijkelkamp Agrisearch Equipment BV

Nijverheidsstraat 30

P.O. Box 4, 6987 ZG Giesbeek

The Netherlands

Telephone +31 313 88 02 00

Fax +31 313 88 02 99

E-mail info@eijkelkamp.com

Internet www.eijkelkamp.com

2 Safety

2.1 Symbols in the manual

**WARNING**

'Warning' identifies a hazard that could lead to personal injury, including death.

**CAUTION**

'Caution' identifies a hazard that could lead to damage to the machine, damage to other equipment and/or environmental pollution.

**Note**

'Note' is used to highlight additional information.

2.2 Intended use

The modem is designed to communicate with sensors (e+ loggers and/or Divers) in the field. The modem has 6 sensor ports, so 6 sensors can be connected to the modem. The user can configure the modem according to his own wishes, for instance regarding measurement interval.

**CAUTION**

The modem has class IP67 protection. This means the modem is dust protected and resistant against temporary immersion. The temporary immersion must not exceed 30 minutes, at a maximum of 1 meter under water. Do not continuously submerge in water.

When there is water inside the enclosure, contact Eijkelkamp.

**CAUTION**

Every other or further use is not in conformance with the intended use.

2.3 Qualification of the user

The user should have a general knowledge about the use of a computer system and computer programs. For the basic maintenance work a general technical background is required.

2.4 Liability

The modem is delivered factory sealed with IP67 protection class.



CAUTION

Do not open the modem in the field. Only open the modem in a clean and dry environment. Avoid unnecessary opening of the modem.

The IP67 protection class can only be preserved and guaranteed when the following parts are clean, dust-free and undamaged:

- enclosure;
- sealing of the enclosure;
- protection caps;
- sealing rubber inside the protection caps;
- all connectors.

Furthermore, make sure that:

- The sealing rubber is present inside the protection caps.
- The protection caps are properly connected to unused connectors.
- The sensor cables are correctly connected. Refer to 4.2.3.
- The modem is mounted to a flat surface to prevent deformation. Refer to 4.2.1.
- The work is performed according to the local ESD safety regulations.
- Only original Eijkelkamp parts are used.

2.5 Regulations and instructions

2.5.1 Modem



WARNING

- Do not use the modem when it is wet or moisty inside the enclosure.
- Dry a wet or moisty modem with a dry, lint-free cloth. Do not dry the modem in any other way.



Note

Never take a battery pack or a modem with an installed battery pack with you as luggage during a flight. Due to severe civil aviation regulations (class 9 dangerous goods), it is forbidden to take a battery pack with you during a flight. The battery pack, or modem with battery pack enclosed, should be officially packaged with the necessary certificates and send by air cargo. Make sure that you comply with the aviation regulations.

2.5.2 Battery pack

The battery pack contains Lithium metal batteries. These batteries have a high energy density so they must be handled with care. Incorrect usage could lead to overheating and explosion.



WARNING

- Do not use a damaged battery pack.
- Keep the battery pack away from fire or heating source.
- Do not submerge the battery pack in water.
- Always use the correct battery pack. Only use original parts.
- Do not short circuit the battery pack.
- Do not charge the battery pack.



Note

Never take a battery pack or a modem with an installed battery pack with you as luggage during a flight. Due to severe civil aviation regulations (class 9 dangerous goods), it is forbidden to take a battery pack with you during a flight. The battery pack, or modem with battery pack enclosed, should be officially packaged with the necessary certificates and send by air cargo. Make sure that you comply with the aviation regulations.

2.5.3 External power supply



WARNING

- Always use the correct power supply and voltage. Refer to 3.4.2.
- Do not use worn and/or damaged cables.

2.5.4 Connection



WARNING

Do not use worn and/or damaged cables.

2.6 Environment and disposal of waste



CAUTION

Always observe the local rules and regulations with respect to processing or disposing of (non-reusable) parts.



CAUTION

Always first remove the battery pack. Refer to 5.4. For correct disposal of the battery pack, refer to 2.6.2.

2.6.1 Correct disposal of the product



WARNING

Do not dispose with other types of waste! This could possibly cause harm to the human health or the environment.

If worn, damaged or not necessary anymore, please return the modem to your local dealer for correct disposal or repair.

2.6.2 Correct disposal of the battery pack



WARNING

Do not dispose with other types of waste! The battery pack contains substances that can cause harm to the human health or the environment.

To protect natural resources and promote material reuse, separate batteries from other types of waste and recycle them through your local battery return system. If not possible, return the battery pack to your local dealer.



CAUTION

Never return the battery pack to the local dealer by air transport because the battery pack contains lithium.

3 Product overview

3.1 Outside view

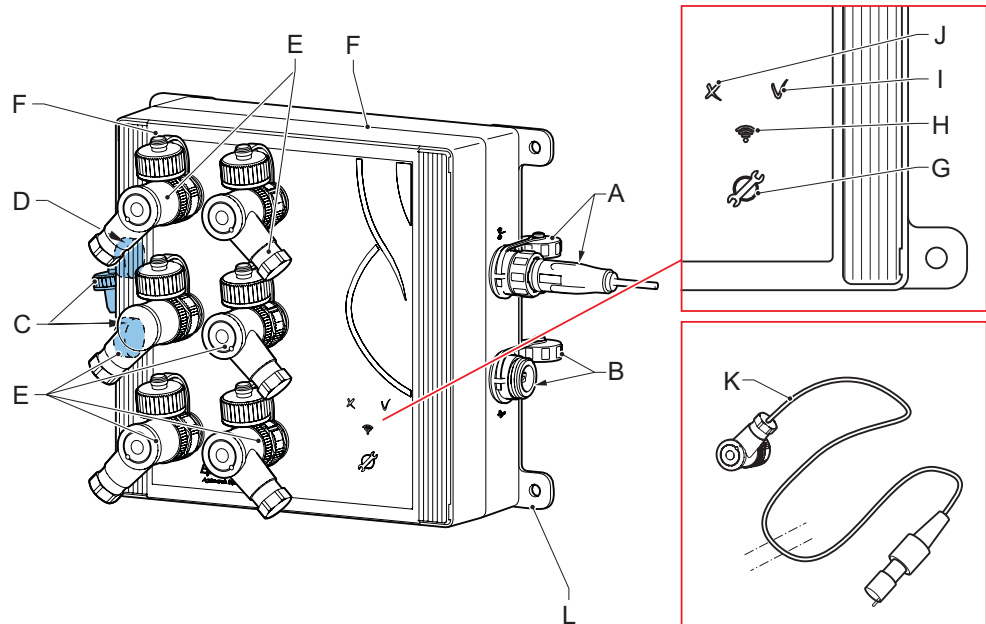

- A Antenna connector³⁾
- B USB port³⁾
- C Power connector³⁾ (M12 4-pole female connector, A-coded)
- D Vent
- E 6 sensor ports³⁾ (M12 4-pole male connector, A-coded)
- F Enclosure
- G Service button
- H GSM signal strength LED
- I Connection LED
- J Error LED
- K Sensor cable
- L Mounting bracket



CAUTION

The modem has class IP67 protection. This means the modem is dust protected and resistant against temporary immersion. The temporary immersion must not exceed 30 minutes, at a maximum of 1 meter under water. Do not continuously submerge in water.

When there is water inside the enclosure, contact Eijkelkamp.

3) Including a waterproof protection cap.

3.2 Inside view

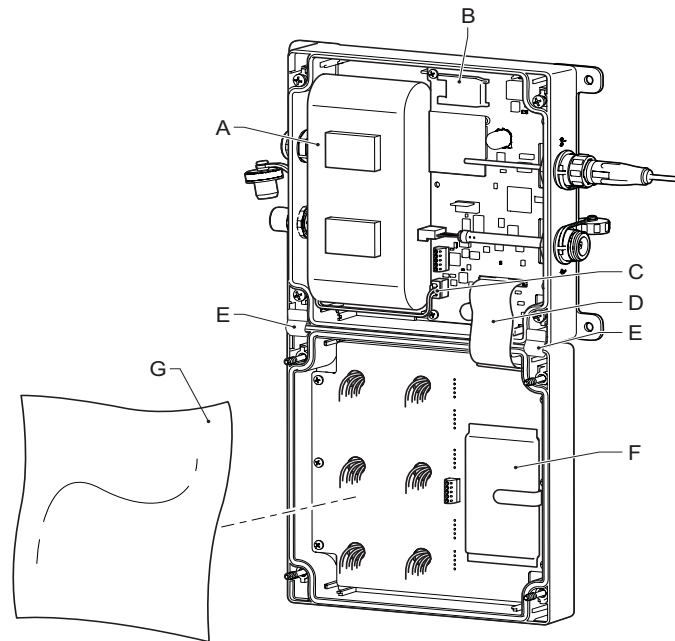

- A Battery pack
- B SIM card (in SIM card holder)
- C Battery pack connector
- D Flat cable
- E Hinges
- F Desiccant bag (fixed by a clip)
- G Humidity Indicator Card

3.3 Explanation of the controls

The controls consist of a service button and three LEDs (connection, error and GSM signal strength). Refer to 3.3.2, 3.3.3 and 3.3.4 for the explanation of the LEDs.

After the service button is pressed, the LEDs show the status of the modem after the connection has been established (or if it has failed). To save energy, the LEDs will be automatically disabled after about 15 seconds once a successful connection has been established, or after an error has occurred.



Note

The LEDs are always OFF until the service button is pressed.



Note

When the battery pack is connected to the modem:

- *The modem will behave as if the service button was pressed;*
- *All LEDs will briefly go on to indicate the modem is powered.*

Product overview

3.3.1 Service button

The Service button is used to initially turn on the modem and afterwards to establish a connection to the Back Office. The Service button can be recognised by the following icon



When the service button is pressed:

- The connection LED will start to blink;
- The modem immediately starts to connect to the Back Office.
- If the modem is connected to a computer by means of a USB connection, the modem will immediately connect to the computer.



Note

It is not possible to turn off the modem by pressing the service button.

3.3.2 Connection LED

The Connection LED shows the status of the connection with the Back Office. The Connection LED can be recognised by the following icon .

	Description
Blinking (green)	The modem is busy connecting to the Back Office.
ON (green)	The modem is connected to the Back Office.
OFF	The modem is not connected to the Back Office.

3.3.3 Error LED

The Error LED indicates that there is an error. The Error LED can be recognised by the following icon .

	Description
Blinking (red)	An error occurred.
OFF	There are no errors.

3.3.4 GSM signal strength LED

The GSM signal strength LED gives an indication of the GSM network coverage at the installation location. The GSM signal strength LED can be recognised by the following icon



	Description
Green	The measured GSM signal strength is okay.
Yellow	The measured signal strength is low, but sufficient for a connection to the GSM network.
Red	There is no connection possible to a GSM network.
OFF	Signal strength has not (yet) been measured.

3.4 Technical data

3.4.1 Mechanical specifications

Dimensions	Specification
Enclosure (LxWxH)	160x160x60 mm
Enclosure with M12-angled sensor connector and antenna connector (LxWxH)	250x160x110 mm
Enclosure with M12-straight sensor connector and antenna connector (LxWxH)	250x160x140 mm

Weight	Specification
Modem (including battery pack)	approx. 1200 g.

Material(s)	Specification
Enclosure	ABS
Mounting brackets	stainless steel

3.4.2 Electrical specifications

Item	Specification
Battery pack (internal)	7.2 V (Lithium metal)
Power supply (external)	DC 5.5 - 18 V
Life time of the battery pack	> 3 years (at a 1 hour wake-up interval)
Maximum rated power usage	4.2 W (800 mA)
Modem time accuracy	better than 1 minute/day

Product overview

3.4.3 Connections

Messaging	Specification
Message mode	web portal, e-mail, SMS alarm, other
GSM	Quadband type (850, 900, 1800, 1900 MHz)
UMTS (optional)	2100 MHz
SIM card	Vodafone NL M2M ^{*)}
Antenna connector	SMB connector
Sensor port	4-pin male connector (with possibility to connect a 5-pole contra-connector), A-coded
External power connector	4-pin female connector, A-coded
USB port ^{**)}	mini USB buccaneer type B receptacle

^{*)} The SIM card is exchangeable by user. Only the SIM cards [@ | A | B | X | a | e | } ^ A | G | T | A | A] guaranteed only after the functionality tests are fulfilled by Eijkelkamp. Use tested cards only.

^{**)} For service purposes only.

Integrated barometer sensor	Specification
Barometer measuring range	10 ... 1200 mbar ^{*)}
Resolution	0.01 mbar
Accuracy barometer	±2 mbar (at 300 ... 1100 mbar, 0 ... 50 °C)
Temperature measuring range	-40 ... +85 °C
Resolution	0.01 °C
Accuracy temperature	± 0.8 °C (at 25 °C) ± 2.0 °C (0 ... 50 °C)

^{*)} 1 mbar is approximately 1 cmH₂O

Antenna ^{*)}	Specification
GSM	Quadband type (850, 900, 1800, 1900 MHz)
UMTS (optional)	2100 MHz
Connector	Bulgin buccaneer SMB (RG-174 coaxial cable)
Ingress Protection	IP67 or better

^{*)} Other antenna types are available on request.

Sensor ports	Specification
Number of sensor ports	6
Port 1 - 6	sensor (e+ logger or Diver) via sensor cable

3.4.4 Ambient conditions

Item	Specification
Temperature (operating range)	-20 ... +50 °C
Ingression protection (enclosure)	IP67 (30min.@1mH ₂ O)
Max. operation height	2000 m

3.4.5 Certifications

Item	Specification
CE	CE compliant
EMC/ESD	EN 61000-6-1, EN 61000-6-3

4 Getting started

4.1 Unpacking

1. When unpacking, carefully follow the instructions as given on the packaging or on the product.
2. Check that your delivery is correct and complete. Refer to the order list and the delivery list. If incomplete, contact Eijkelkamp.



CAUTION

The modem is pre-installed with SIM card and battery pack. It is not necessary to open the modem. Avoid unnecessary opening of the modem because of the risk of leakage.

3. Check the delivery for any transport damage. Report any damage immediately by filing a claim against the carrier and mark the bill of lading accordingly.

4.2 Installation



CAUTION

The guarantee will be void when the modem is not used for its intended use and/or at incorrect installation. Refer to 2.2 and 4.2.

4.2.1 Mounting the modem



CAUTION

- Place the modem in a protective environment. Preferably in an extra enclosure that is waterproof.*)
- Do not expose the modem to direct sunlight.
- Avoid deformation of the enclosure.
 - Do not use too much force when mounting the modem.
 - The mounting surface should be flat in order to have a stable connection. Irregularities will increase the risk of leakage.
 - The mounting surface should be free from dirt.
- Keep the Service button free from pressure.
- All connectors should be easily reachable and there should be enough space to connect the cables to the connectors.
- All parts must be clean and dry prior to installation.
- Do not expose the modem to vibration, direct heat sources and/or forms of radiation and magnetism.

*) If the protective environment is air-tight, the internal barometer data cannot be used. In this case, use the data of another barometer location or external Baro Diver.

1. Drill holes in the surface. Refer to 6.2 for the dimensions.

**Note**

The maximum screw size is 5 mm.

2. Place the modem to the mounting surface.
3. Place and fasten the screws handtight. Use a screwdriver.

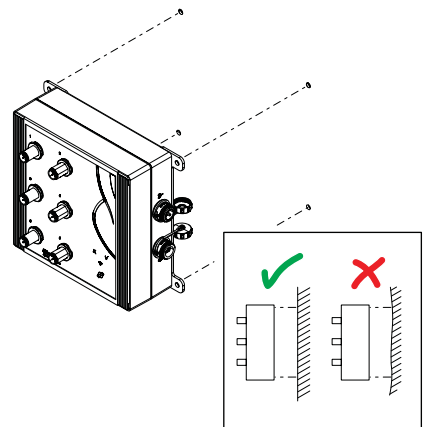

4.2.2 Connecting the antenna

**CAUTION**

All parts must be clean and dry prior to installation.

1. Mount the antenna (D). Refer to the installation instructions of your specific antenna.
2. Open the protection cap (B) by turning it counter clockwise.
3. Connect the antenna (D) to the antenna connector (A). Press it to the antenna connector until you hear a click sound.

**CAUTION**

Do not use force.

4. Fasten the antenna by turning the locking ring (C) clockwise.

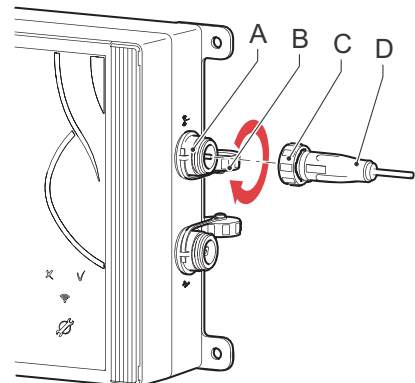

Getting started

4.2.3 Connecting a sensor cable



CAUTION

All parts must be clean and dry prior to installation.

1. Open the protection cap (A) by turning it counter clockwise.
2. Connect the sensor cable (B) to the sensor port.



CAUTION

Do not use force. There is only one way to connect the cable to the sensor port. Always check the position of the positioning cam (C).

3. Fasten the sensor cable by turning the locking ring (D) clockwise.



CAUTION

Do not fasten the cables too tight onto the connectors. Use your thumb and index finger. For internally clean connectors, the IP67 protection class is guaranteed at a torque of 0.6 Nm.

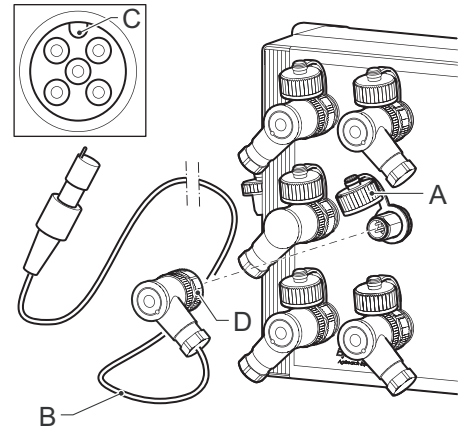

4.2.4 Connecting the external power supply (optional)



WARNING

The external power supply must be OFF.
The power supply must be DC 5.5 - 18V. Refer to 3.4.2.



CAUTION

All parts must be clean and dry prior to installation.

1. Open the protection cap (A) by turning it counter clockwise.
2. Connect the power cable (B) to the power connector.



CAUTION

Do not use force. There is only one way to connect the power cable to the power connector. Always check the position of the positioning cam (C).

3. Turn on the external power supply.

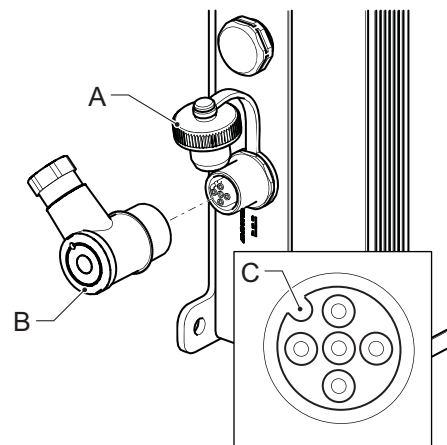

4.3 Commissioning

1. Press the service button (A). The LEDs will go ON.



Note

The LEDs should go ON. Refer to 3.3 to see which status the LEDs indicate.

The Back Office will activate the connected sensor(s).

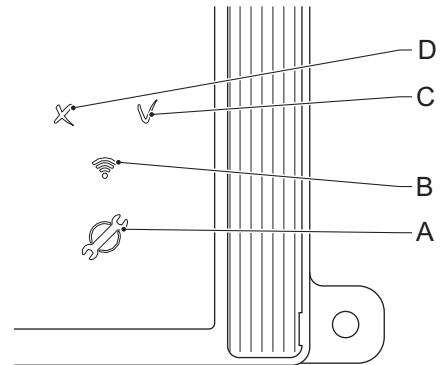

5 Maintenance

5.1 Preparation



CAUTION

Only original parts must be used, otherwise the guarantee will be void.

Make sure you take with you the following tools and accessories:

- Crosshead screwdriver (PZ-2 Pozi);
- Cloth (clean, dry and lint-free);
- Replacement desiccant kit. A desiccant kit contains a desiccant bag and a Humidity Indicator Card. Refer to 6.1.
- Replacement battery pack. Refer to 6.1.
- Replacement SIM card (optional).
- Replacement antenna.
- Replacement cables and sensors.

5.2 General inspection overview

The modem requires little maintenance. However, if you need to do maintenance work, always check the following points during maintenance.



Note

It is advised always to take a replacement battery pack with you. Check the battery capacity level beforehand via the web portal or the e-mail functionality. Refer to Supplement 1 or 2 on how to check the battery capacity level.



Note

Never take a battery pack or a modem with an installed battery pack with you as luggage during a flight. Due to severe civil aviation regulations (class 9 dangerous goods), it is forbidden to take a battery pack with you during a flight.

Inspection	Check	Action (if required)
Enclosure (external)	Dirt / Humidity	Clean and dry with a dry, lint-free cloth.
Enclosure (internal)	Humidity	Replace the desiccant kit. Refer to 5.3.6. If wet or moisty, contact Eijkelkamp.
Sensor cables	Wear or damage	Replace the cables.
Antenna	Wear or damage	Replace the antenna.
SIM card		Refer to 5.5.

5.3 Inspection and cleaning

5.3.1 Inspecting and cleaning the outside of the modem



Note

Make sure that the modem is in power OFF mode. Refer to Supplement 1 or 2 on how to put the modem in the power OFF mode.

1. If an external power supply is used,



WARNING

The external power supply must be OFF.

- a. Turn off the external power supply.
 - b. Disconnect the power cable from the power connector. Turn the locking ring counter clockwise. Refer to 4.2.4.
 - c. Clean the power connector and its protection cap with a dry, lint-free cloth.
 - d. Check the rubber seal inside the protection cap. It must be undamaged and clean.
 - e. Place the protection cap.
2. Check the outside of the modem for dirt and humidity.
 3. Clean and dry the modem with a dry, lint-free cloth.

5.3.2 Dismounting the modem



Note

If you need to open the enclosure, it is advised to dismount the modem from the mounting surface, so the modem can be taken to a clean and dry environment.

1. Check if all cables and connectors are still connected correctly. Also check all cables and connectors for possible defects.
2. Disconnect the antenna from the antenna connector. Turn the locking ring counter clockwise.
3. Disconnect the sensor cables from the sensor ports. Turn the locking rings counter clockwise.
4. Clean the antenna connector and sensor ports with a dry, lint-free cloth.
5. Check the rubber seals inside the protection caps. They must be undamaged and clean. Clean the protection caps.
6. Place the protection caps onto the antenna connector and sensor ports.
7. Loosen the screws by turning them counter clockwise.
8. Remove the modem from the mounting surface.
9. Take the modem to a clean and dry environment.

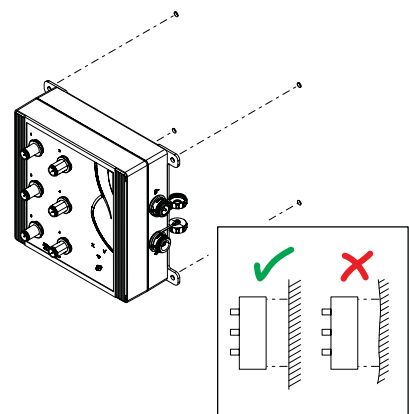

Maintenance

5.3.3 Opening the enclosure



CAUTION

Do not open the modem in the field. Only open the modem in a clean and dry environment.



Note

It is advised not to open the enclosure unless it is really necessary. Opening the enclosure increases the risk of leakage afterwards.

1. Remove the covering strips (A). Use your finger nail in position of the gaps (B).

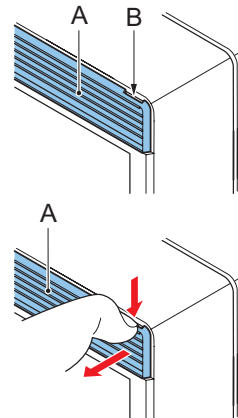

2. Loosen the screws (C). Use the crosshead screwdriver (PZ-2 Pozi). Refer to 5.1.

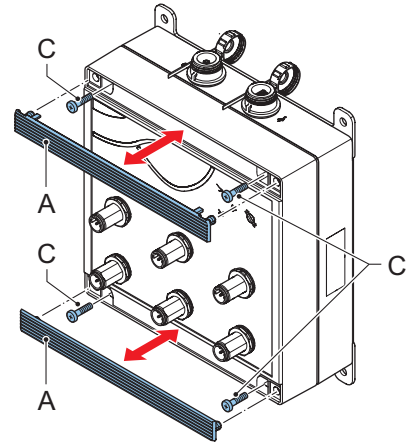

3. Place the modem on a flat surface, such as a table.
4. Open the enclosure. Carefully flip the front cover to the side.



CAUTION

The front and back cover are connected to each other by hinges (A) and a flat cable (B). Be careful when opening the modem. Do not use force.

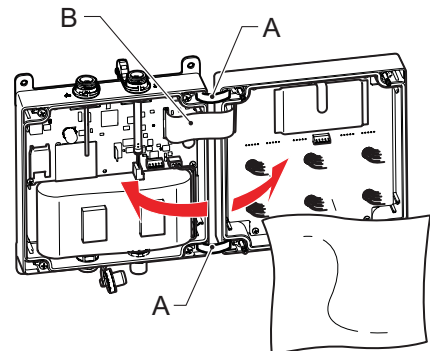

5.3.4 Checking the Humidity Indicator Card



CAUTION

When opening the modem, always check the Humidity Indicator Card immediately. If the inside of the modem is moisty or wet, the electronics might be wet and thus the risk of the modem being damaged is high. So, the higher the humidity level, the higher the risk of damage.



Note

- The "Current Humidity Indicator" (at the lower part of the card) indicates the current relative humidity level (RH) in the inside of the modem.
- The "Maximum Humidity Indicator" (at the upper part of the card) indicates the maximum relative humidity level (RH) that occurred in the inside of the modem over a range of approximately 24 hours.
- A full explanation about how to read the Humidity Indicator Card can be found on the card itself.

1. Remove the Humidity Indicator Card.
2. Check the Humidity Indicator Card.



Note

The ideal RH for electronics is between 40 and 60%. When the "Current Humidity Indicator" displays an RH of about 60-70%, it is most likely that there is a moisture problem inside the modem and action must be taken.

3. If the Humidity Indicator Card displays an RH of above 60%, the following steps must be taken:
 - a. Inspect the condition of the modem and the sealing of the enclosure and dust caps. There should be no damage.
 - b. Contact Eijkelkamp.

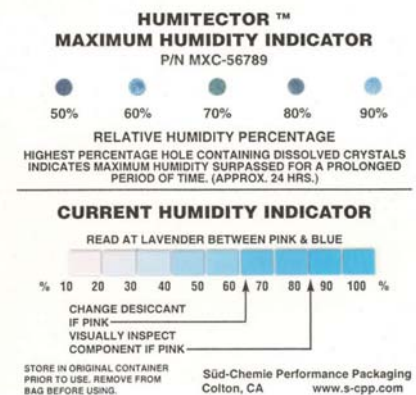

5.3.5 Inspecting and cleaning the inside of the modem

1. Check the inside of the modem for dirt, dust, humidity and damage. Pay special attention to the sealing of the front cover and the flash ridge.



WARNING

The modem must be free from dirt, dust, humidity and damage. Only clean the seal and flash ridge with a clean lint-free cloth if necessary. Never touch the electronics of the printed circuit board (PCB)!

2. Check the sealing edges (A) in the front and back cover. The sealing edges must be free from dirt and damage (e.g. burrs).
3. If required, clean the sealing edges with a lint-free cloth and some solvent, such as benzene, brake cleaner or something similar.



CAUTION

Do not use greasy substances and agents, such as white spirit, acetone or thinner.

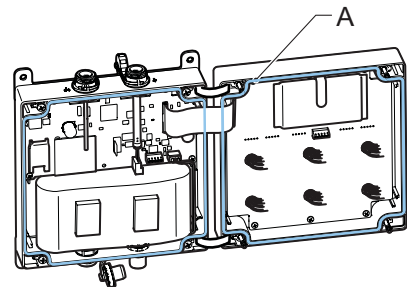

5.3.6 Replacing the desiccant kit



CAUTION

Only use original parts. A new desiccant kit can be ordered at Eijkelkamp. Refer to 6.1.



CAUTION

Act quickly during the replacing of the desiccant kit!

1. Open the clip of the desiccant holder (B).
2. Remove the old desiccant bag (A).
3. Place the new desiccant bag into the desiccant holder.



CAUTION

The new desiccant bag must be taken out of its package at the last moment. It must be protected against all kinds of moisture before it is placed in the dry enclosure of the modem.

4. Close the clip of the desiccant holder.
5. Place the new Humidity Indicator Card in the enclosure.

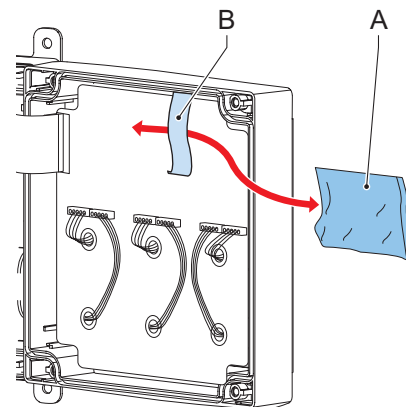

Note

Place the Humidity Indicator Card onto the battery pack with the text facing upward. This way the Humidity Indicator Card can quickly and directly be read when the enclosure will be opened the next time.



CAUTION

Make sure the Humidity Indicator Card will not get stuck between the front and back cover of the enclosure. This will increase the risk of leakage and/or deformation!

6. Close the enclosure immediately. See 5.3.7.

5.3.7

Closing the enclosure

1. Close the enclosure.



CAUTION

The front and back cover of the enclosure are connected to each other by hinges (A) and a flat cable (B). Be careful when closing the enclosure. Do not use force.

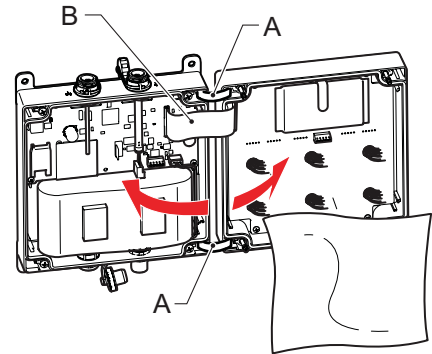

2. Fasten the screws (C) clockwise. These screws must be fastened evenly, crosswise and hand tight. Use the crosshead screwdriver (PZ-2 Pozi). Refer to 5.1.
3. Fasten the strips (A).



Note

You should hear a click sound.

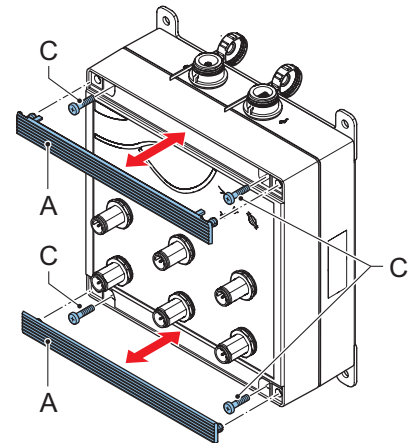

5.3.8 Mounting the modem

1. Check the mounting surface. If necessary, clean the mounting surface and the holes.



CAUTION

Avoid deformation of the enclosure.

- Do not use too much force when mounting the modem.
- The mounting surface should be flat in order to have a stable connection.
- The mounting surface should be free from dirt.

2. Place the modem to the flat mounting surface.
3. Fasten the screws handtight by turning them clockwise.
4. Connect the antenna to the antenna connector. Refer to 4.2.2.
5. Connect the sensor cables to the sensor ports. Refer to 4.2.3.
6. If an external power supply is used,



WARNING

Always check beforehand if the power supply is OFF.

- a. Connect the power cable to the power connector. Refer to 4.2.4.
 - b. Turn on the external power supply.
7. Start the commissioning process. Refer to 4.3.

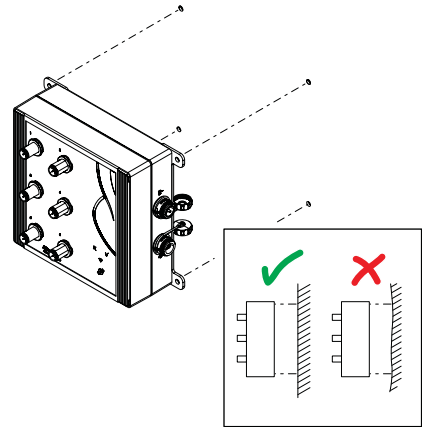

5.4 Replacing the battery pack



Note

Use original parts. A new battery pack can be ordered at Eijkelkamp. Refer to 6.1.

1. Follow all procedures of 5.3.1 to 5.3.5.
2. Disconnect the battery connector (A).



CAUTION

Work according to your local ESD safety regulations. Avoid touching the printed circuit board (PCB).



Note

All setting changes that have not yet been saved will be lost when the battery pack is disconnected.

3. Carefully remove the empty battery pack (B) from the Velcro.
4. Place the replacement battery pack.



CAUTION

Prevent contact between the battery pack and the PCB.



Note

Make sure the battery pack is placed in the correct position. Refer to the figure. The battery connector (A) must easily reach the connector on the modem (C).

5. Connect the battery connector.



Note

When the battery pack is connected to the modem:

- The modem will behave as if the service button was pressed;
- All LEDs will briefly go on to indicate the modem is powered.

6. Follow all procedures of 5.3.6 to 5.3.8.
7. Dispose of the old battery pack in a proper way. Refer to 2.6.2.

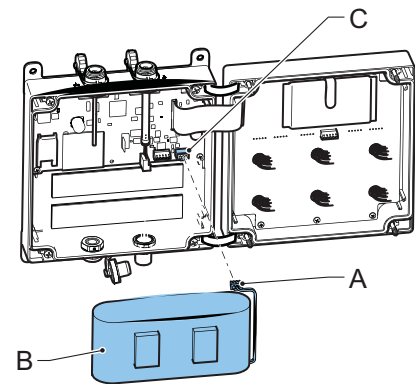

5.5 Replacing the SIM card (optional)



WARNING

Always disconnect the external power supply and battery pack before replacing the SIM card.



CAUTION

Make sure that the PIN code of the SIM card is turned off or set to the desired PIN code.



Note

If a PIN code is used, make sure that the PIN code that was configured in the modem is identical to the PIN code of the SIM card.

1. Follow all procedures of 5.3.1 to 5.3.5.
2. Disconnect the battery connector. Refer to 5.4.
3. Slide the holder (B) in the open position. Refer to step 1 in the figure.
4. Pull up the holder. Refer to step 2 in the figure.
5. Remove the SIM card (A) from the holder. Refer to step 2 in the figure.
6. Place the new SIM card into the holder. Refer to step 4 in the figure.
7. Push back the holder. Refer to step 4 in the figure.
8. Slide the holder in the closed position. Refer to step 5 in the figure.
9. Connect the battery connector. Refer to 5.4.
10. Follow all procedures of 5.3.6 to 5.3.8.

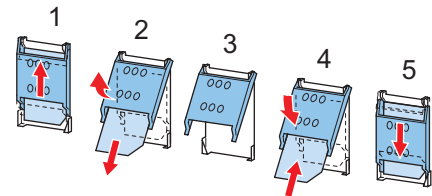
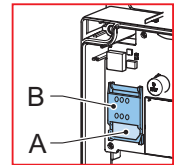

5.6 Storage



CAUTION

Do not place the modem in a humid and dusty environment.

Do not place any heavy materials on top of the modem.

1. Clean the outside of the modem. Refer to 5.3.1.
2. Dismount the modem. Refer to 5.3.2.
3. Store the modem in a clean and dry place.



Note

If a modem is not to be used for a longer period of time, it is important that the modem will be set in the power OFF mode via the web portal or e-mail functionality. Refer to Supplement 1 or 2 on how to put the modem in the power OFF mode.

In case the modem will not be used for very long period of time, it is also advised to disconnect the battery pack. Even if the modem is in the power OFF mode, it actually continues to draw a minimum amount of current and thus drains the battery.

However, it is also advised not to open the enclosure of the modem unless you really need to do so. Opening the enclosure increases the risk of leakage afterwards. Consider whether the battery pack needs to be disconnected or not.

If the battery pack needs to be disconnected, refer to step 1 and 2 of 5.4.

6 Specifications

6.1 Parts list



CAUTION

Only original parts must be used, otherwise the guarantee will be void.

Article number	Part name
11.32.01	Global Data Transmitter Multiple GSM/GPRS
11.32.02	Global Data Transmitter Multiple UMTS
11.32.20	Battery pack
11.32.32	Robust external antenna
11.32.33	Rod antenna
11.32.40	Power supply (EURO, UK, USA/Japan, Australia, IEC)
11.32.51	Overground housing
11.32.96.01	Desiccant kit (contains desiccant bag and Humidity Indicator Card)
11.62.01	SIM card (The Netherlands)
11.62.02	SIM card (Europe zone)
11.62.02.01	SIM card (Rest of the World zone)
H503011	Protection cap for sensor port (M12, male)
H503013	Protection cap external power supply connector (M12; female)
H503038	Protection cap for USB port connector
H503038	Protection cap for antenna connector

6.2 Dimensions

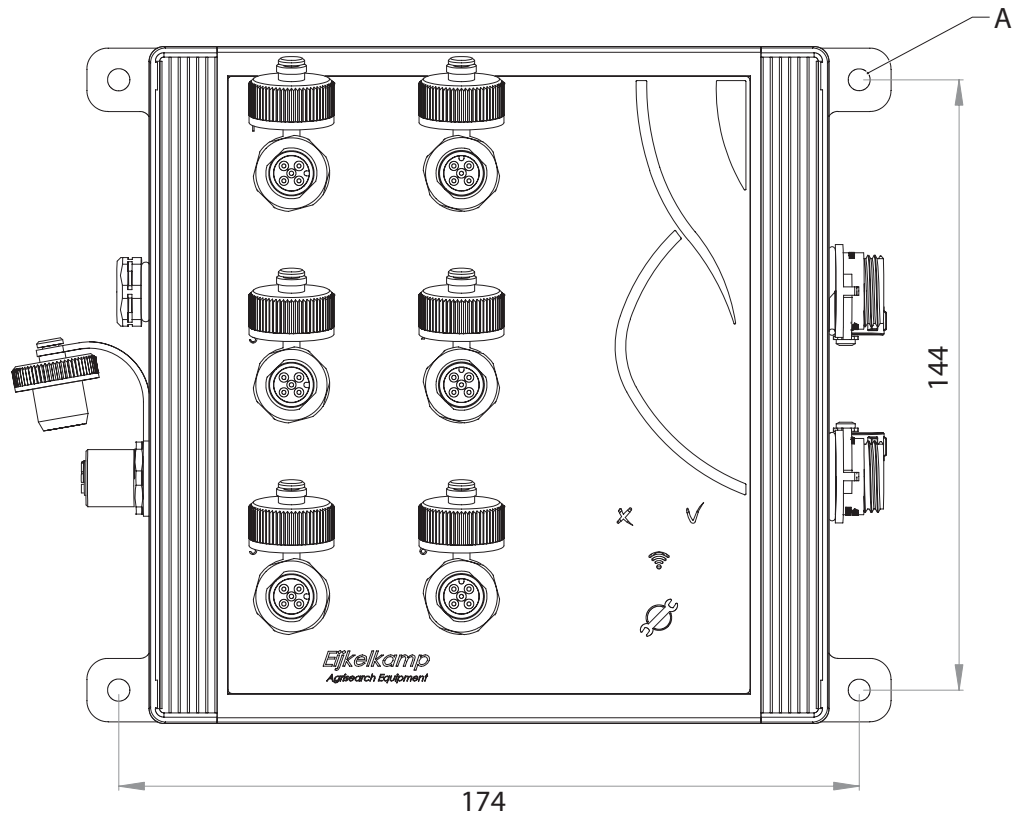

A Max. Ø for 5 mm screws.

Declaration of Conformity

7 Declaration of Conformity

7.1 EC Declaration GSM / GPRS



EC Declaration of Conformity

The undersigned, representing the manufacturer:

Eijkelpark Agrisearch Equipment BV
Nijverheidsstraat 30
6987 EM Giesbeek
The Netherlands

Herewith declare that the product:

Type: e-SENSE Wallmount modem (Quad-Band GSM/ GPRS)
Art.nr.: 11.32.01
Function(s): connecting element between sensors (e+loggers and divers) and the Back Office in the e-SENSE system.
The most important functions of the modem:
- Passing through the collected data of the connected sensors to the Back Office;
- Enabling remote monitoring of the connected sensors.

is in conformity with the essential requirements of the following EC Directive(s) when installed in accordance with the installation instructions contained in the product documentation:

- a) 2004/108/EC EMC Directive
- b) 1999/5/EC R&TTE (**applies only the GSM/ GPRS module; Cinterion Wireless Module TC63i**)
- c) 2002/96/EC Waste Electrical and Electronic Equipment (WEEE)
- d) 2002/95/EC RoHS Directive



and that the standards and/or technical specifications referenced below have been applied:

- a) **EMC-Directive:**
EN 61000-6-1:2007 *Generic standards - Immunity standard for residential, commercial and light-industrial environments, from which:*
 - EN 61000-4-2:2009 Electrostatic discharge (ESD) immunity test
 - EN 61000-4-3:2006/ A1:2008/ A2:2010 Radiated, radio-frequency, electromagnetic field immunity test
 - EN 61000-4-4:2004/ A1:2010 Electrical fast transient (EFT)/ burst immunity test
 - EN 61000-4-5:2006 Surge immunity test
 - EN 61000-4-6:2009 Immunity to conducted disturbances, induced by radio-frequency fields
 - EN 61000-4-8:2010 Power frequency magnetic field immunity test
- EN 61000-6-3:2007 + A1:2011 *Generic standards - Emission standard for residential, commercial and light-industrial environments*
- b) **R&TTE Directive: (applies only the GSM/ GPRS module; Cinterion Wireless Module TC63i)**
GCF-CC V3.42.2: A Certification Criteria Version (CC-Version) is a list of valid tests that has to be performed to obtain a certification for a mobile device.
 - ETSI EN 301 511 V9.0.2 : Global System for Mobile communications (GSM); Harmonized EN for mobile stations in the GSM 900 and GSM 1800 bands covering essential requirements under article 3.2 of the R&TTE directive (1999/5/EC)
 - ETSI EN 301 489-1 V1.8.1 : Electromagnetic compatibility and Radio spectrum Matters (ERM); Electro Magnetic Compatibility (EMC) standard for radio equipment and services; Part 1: Common technical requirements
 - ETSI EN 301 489-7 V1.3.1: Electromagnetic compatibility and Radio spectrum Matters (ERM); Electro Magnetic Compatibility (EMC) standard for radio equipment and services; Part 7: Specific conditions for mobile and portable radio and ancillary equipment of digital cellular radio telecommunications systems (GSM and DCS)
 - NEN-EN-HEC 60950-1: 2006/ A11:2009: Information technology equipment - Safety - Part 1: General requirements

Giesbeek, 16-Nov.-2012

Manufacturer:

Signature

Fons Eijsink
Technical Director

7.2 EC Declaration UMTS



EC Declaration of Conformity

The undersigned, representing the manufacturer:

Eijkelkamp Agrisearch Equipment BV
Nijverheidsstraat 30
6987 EM Giesbeek
The Netherlands

Herewith declare that the product:

Type: e-SENSE Wallmount modem (UMTS; Five-Band 3G)
Art.nr.: 11.32.02
Function(s): connecting element between sensors (e-loggers and divers) and the Back Office in the e-SENSE system.
The most important functions of the modem:
- Passing through the collected data of the connected sensors to the Back Office;
- Enabling remote monitoring of the connected sensors.

is in conformity with the essential requirements of the following EC Directive(s) when installed in accordance with the installation instructions contained in the product documentation:

- a) 2004/108/EC EMC Directive
- b) 1999/5/EC R&TTE (**applies only the UMTS module; Cinterion Wireless Module PH8**)
- c) 2002/96/EC Waste Electrical and Electronic Equipment (WEEE)
- d) 2002/95/EC RoHS Directive



and that the standards and/or technical specifications referenced below have been applied:

- a) **EMC-Directive:**
EN 61000-6-1:2007 *Generic standards - Immunity standard for residential, commercial and light-industrial environments, from which:*
 - EN 61000-4-2:2009 Electrostatic discharge (ESD) immunity test
 - EN 61000-4-3:2006/ A1:2008/ A2:2010 Radiated, radio-frequency, electromagnetic field immunity test
 - EN 61000-4-4:2004/ A1:2010 Electrical fast transient (EFT)/ burst immunity test
 - EN 61000-4-5:2006 Surge immunity test
 - EN 61000-4-6:2009 Immunity to conducted disturbances, induced by radio-frequency fields
 - EN 61000-4-8:2010 Power frequency magnetic field immunity test
- EN 61000-6-3:2007 + A1:2011 *Generic standards - Emission standard for residential, commercial and light-industrial environments*
- b) **R&TTE Directive: (applies only the UMTS module; Cinterion Wireless Module PH8)**
ETSI EN 301 511 V9.0.2 : Global System for Mobile communications (GSM); Harmonized EN for mobile stations in the GSM 900 and GSM 1800 bands covering essential requirements under article 3.2 of the R&TTE directive (1999/5/EC)
ETSI EN 300 440-2 V1.3.1: Electromagnetic compatibility and Radio spectrum Matters (ERM); Short range devices; Radio equipment to be used in the 1 GHz to 40 GHz frequency range; Part 2: Harmonized EN covering the essential requirements of article 3.2 of the R&TTE Directive
ETSI EN 301 908-1 V4.2.1: Electromagnetic compatibility and Radio spectrum Matters (ERM); Base Stations (BS), Repeaters and User Equipment (UE) for IMT-2000 Third-Generation cellular networks; Part 1: Harmonized EN for IMT-2000, introduction and common requirements, covering the essential requirements of article 3.2 of the R&TTE Directive
ETSI EN 301 908-2 V4.2.1: Electromagnetic compatibility and Radio spectrum Matters (ERM); Base Stations (BS), Repeaters and User Equipment (UE) for IMT-2000 Third-Generation cellular networks; Part 2: Harmonized EN for IMT-2000, CDMA Direct Spread (UTRA FDD and E-UTRA FDD) (UE) covering the essential requirements of article 3.2 of the R&TTE Directive
ETSI EN 301 489-1 V1.8.1 : Electromagnetic compatibility and Radio spectrum Matters (ERM); Electro Magnetic Compatibility (EMC) standard for radio equipment and services; Part 1: Common technical requirements
ETSI EN 301 489-3 V1.4.1: Electromagnetic compatibility and Radio spectrum Matters (ERM); Electro Magnetic Compatibility (EMC) standard for radio equipment and services; Part 3: Specific conditions for Short-Range Devices (SRD) operating on frequencies between 9 kHz and 246 GHz
ETSI EN 301 489-7 V1.3.1: Electromagnetic compatibility and Radio spectrum Matters (ERM); Electro Magnetic Compatibility (EMC) standard for radio equipment and services; Part 7: Specific conditions for mobile and portable radio and ancillary equipment of digital cellular radio telecommunications systems (GSM and DCS)
ETSI EN 301 489-24 V1.4.1: Electromagnetic compatibility and Radio spectrum Matters (ERM); Electro Magnetic Compatibility (EMC) standard for radio equipment and services; Part 24: Specific conditions for IMT-2000 CDMA Direct Spread (UTRA and E-UTRA) for Mobile and portable (UE) radio and ancillary equipment
NEN-EN-HEC 60950-1: 2006/ A11:2009: Information technology equipment - Safety - Part 1: General requirements
EN 62311:2008 Assessment of electronic and electrical equipment related to human exposure restrictions for electromagnetic fields (0 Hz-300 GHz)

Giesbeek, 16-Nov.-2012

Manufacturer:
Signature

Fons Eijsink
Technical Director



All it takes for environmental research

P.O. Box 4, 6987 ZG Giesbeek **T** +31 313 88 02 00 **E** info@eijkelpark.com
The Netherlands **F** +31 313 88 02 99 **I** www.eijkelpark.com